

Quotation sheet

Item	name	Platform height	Working height	Load (Kg)	Overall Size (m)	Weight kg	FOB Unit price	Qty
CFPT1416	Self propelled scissor lift	13.7m	15.7m	230	2.85*1.28*2.1	3640	USD13800	1
Total							USD13800	

1. Lead time: 10working day
2. 30% deposit the balance is paid before shipment
3. 2 years whole machine warranty and structure 5 years

Specification:

CFPT1416		
	Working Height	15.7m
A	Platform Height	13.7m
	Platform dimension(Length x width)	
C D	Platform Retracted	2640*1120mm
B D	Platform Extended	3540*1120mm
E	Height - Rails up	2635mm
F	Height - Rails folded	2105mm
G	Length - Stowed	2640mm
H	Width	1280mm
	Tyre	Φ381*127mm
Productivity		
	Rated Load Capacity	230Kg
	Extended Platform Capacity	113Kg
	Travel Speed (Stowed)	3.5Km/h
	Travel Speed (Raised)	0.8Km/h
	Turning Radius	0m/2.7m
	Raised/Lower Speed	82/60sec
	Gradeability	25%
	Max.Working Slope	2°/3°
Power		
	Lifting Motor	24V/4.5Kw

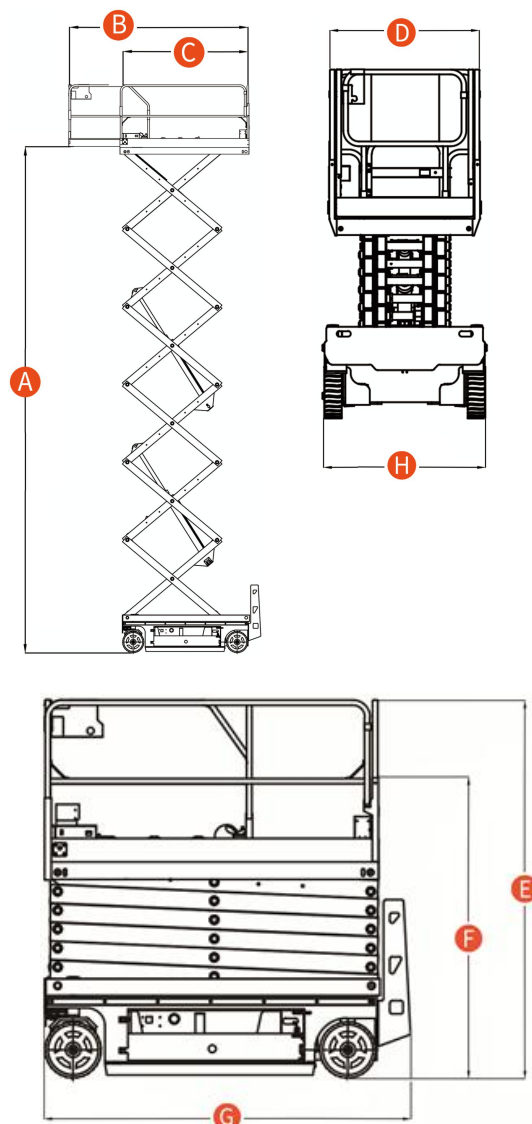

Battery	4*12V/300Ah
Charger	24V/25A
Weight	
Overall Weight	3640Kg
Maximum Works Number	2

Standard Equipment

- Self-lock gate on platform
- Proportional control
- Extension Platform
- Drivable at full height
- Non marking tyre
- 2WD
- Track laying drive system
- Automatic brakes system
- Emergency lowering system
- Emergency stop button
- Tubing explosion-proof system
- Onboard diagnostic system
- Tilt sensor with alarm
- All Motion Alarm
- Horn
- Safety brackets
- Forklift pockets
- Charger protection
- Flashing beacon
- Folding guardrails
- Automatic pothole protection
- Overload alarm



JUXIN MACHINERY CO.,LTD

CONTACT: HELEN SALES04@JXMACHINERY.NET.CN

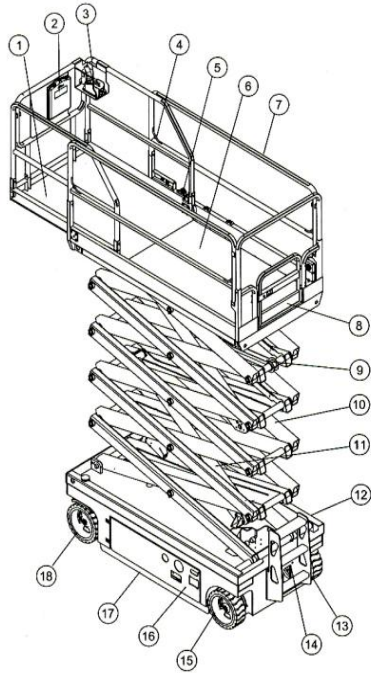

- | | |
|-----------------------------------|--------------------------|
| 1 Extend platform | 2 manual box |
| 3 Platform Controller | 4 lashing fixed point |
| 5 Extended Platform release tread | 6 Fixed platform |
| 7 Guard Rail | 8 Platform entrance door |
| 9 Safety Arm | 10 Scissors arm |
| 11 Lifting hydraulic cylinder | 12 Ground control |
| 13 Ladder | 14 Brake release pump |
| 15 Non steering wheel | 16 Charger |
| 17 Pit Protection device | 18 Steering wheel |

Product Details



Extension platform



Easy maintenance



Brake release



Platform foot lock



Safety brackets



Automatic pothole protection



Platform control

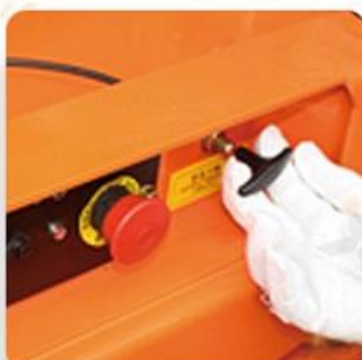

Emergency lowering system



Small turning radius

Packing

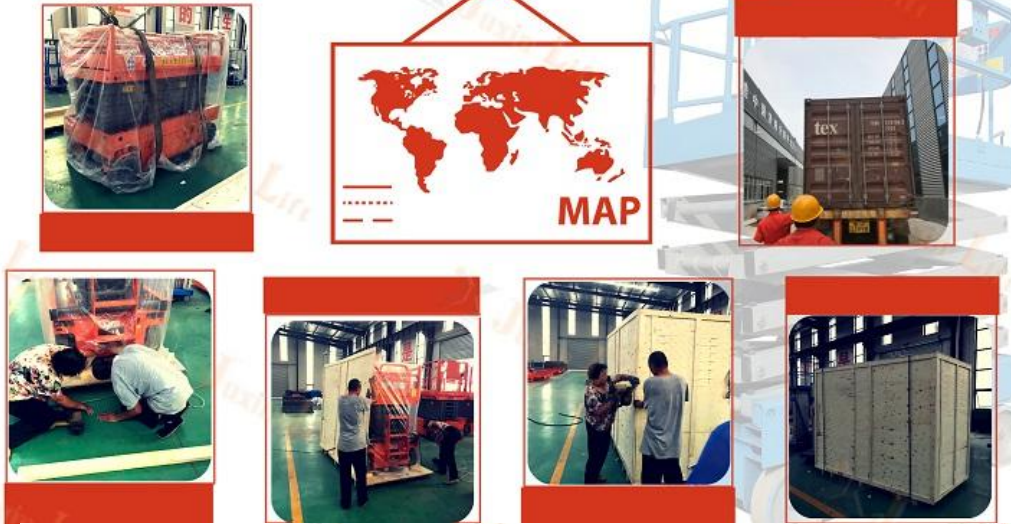

Product Application



CERTIFICATION



Professional manufacturer of automatic walking hydraulic lift



Packing & shipping

Shipping process



Strictly track each step of the process to ensure that the goods reach the place of use safely



Cargo packaging



Cargo loading



Cargo transportation



Buyer receiving

